

REV	DESCRIPTION	DATE	BY
A	Initial release	04/04/11	BBT

This schematic is **\*NOT SUPPORTED\*** and DOES NOT constitute a reference design. Only "community" support is allowed via resources at [BeagleBoard.org/discuss](http://BeagleBoard.org/discuss).

THERE IS NO WARRANTY FOR THIS DESIGN , TO THE EXTENT PERMITTED BY APPLICABLE LAW. EXCEPT WHEN OTHERWISE STATED IN WRITING THE COPYRIGHT HOLDERS AND/OR OTHER PARTIES PROVIDE THE DESIGN "AS IS" WITHOUT WARRANTY OF ANY KIND, EITHER EXPRESSED OR IMPLIED, INCLUDING, BUT NOT LIMITED TO, THE IMPLIED WARRANTIES OF MERCHANTABILITY AND FITNESS FOR A PARTICULAR PURPOSE. THE ENTIRE RISK AS TO THE QUALITY AND PERFORMANCE OF THE DESIGN IS WITH YOU. SHOULD THE DESIGN PROVE DEFECTIVE, YOU ASSUME THE COST OF ALL NECESSARY SERVICING, REPAIR OR CORRECTION.

 <b>beagleboardtoys.com</b>		1380 Presidential Dr. #100 Richardson, TX 75081 <a href="http://www.beagleboardtoys.com">www.beagleboardtoys.com</a>
Title COVER PAGE		
Size B	Document Number BBT-WLAN-SCH-001	Rev A
Date: Monday, April 11, 2011		Sheet 1 of 3

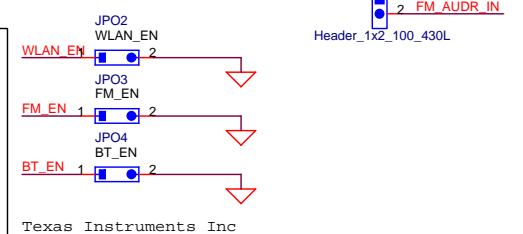
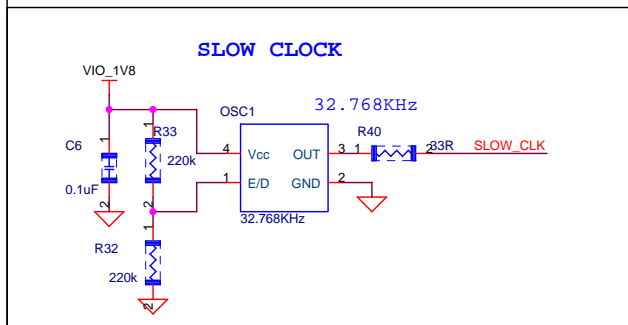
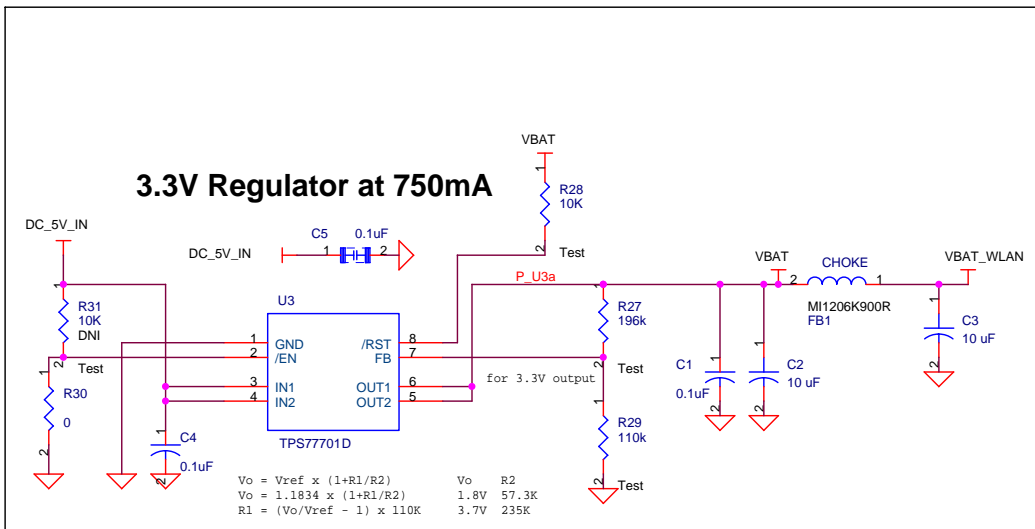
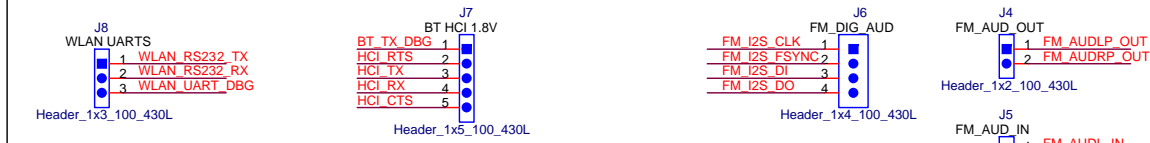
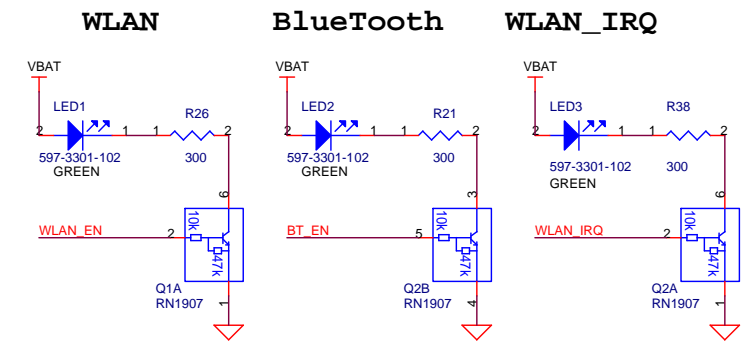
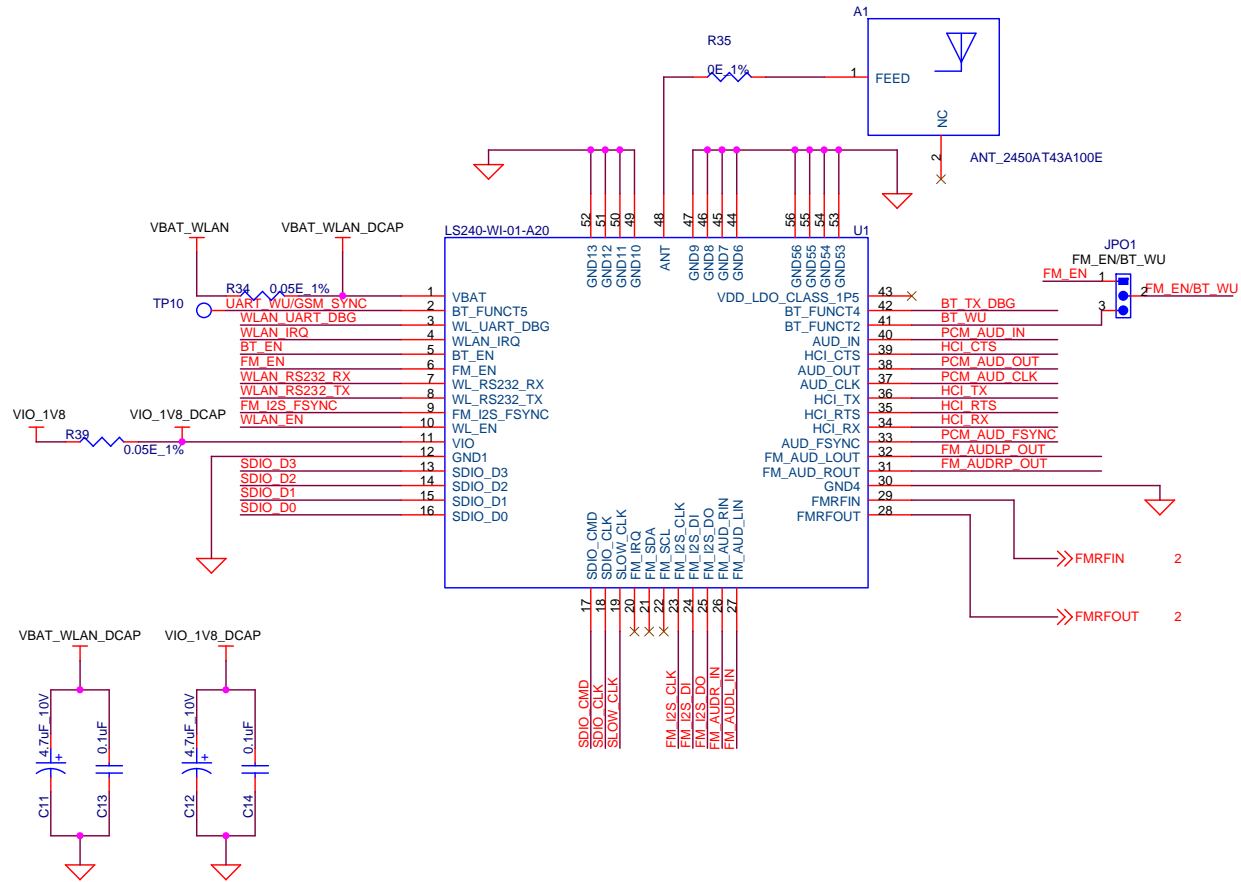
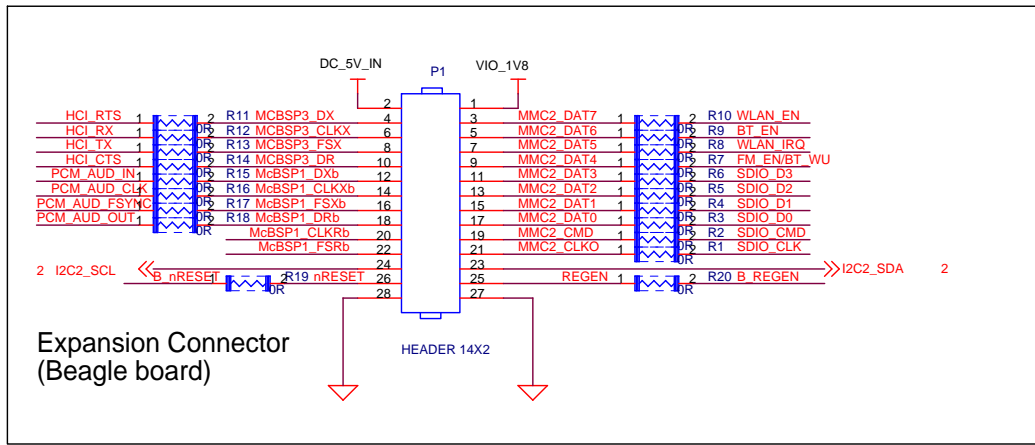

**beagleboardtoys.com**

1380 Presidential Dr. #100  
 Richardson, TX 75081  
 www.beagleboardtoys.com

Title		WLAN	
Size	Document Number	Rev	
A	BBT-WLAN-SCH-001	A	
Date:	Monday, April 11, 2011	Sheet	2 of 3

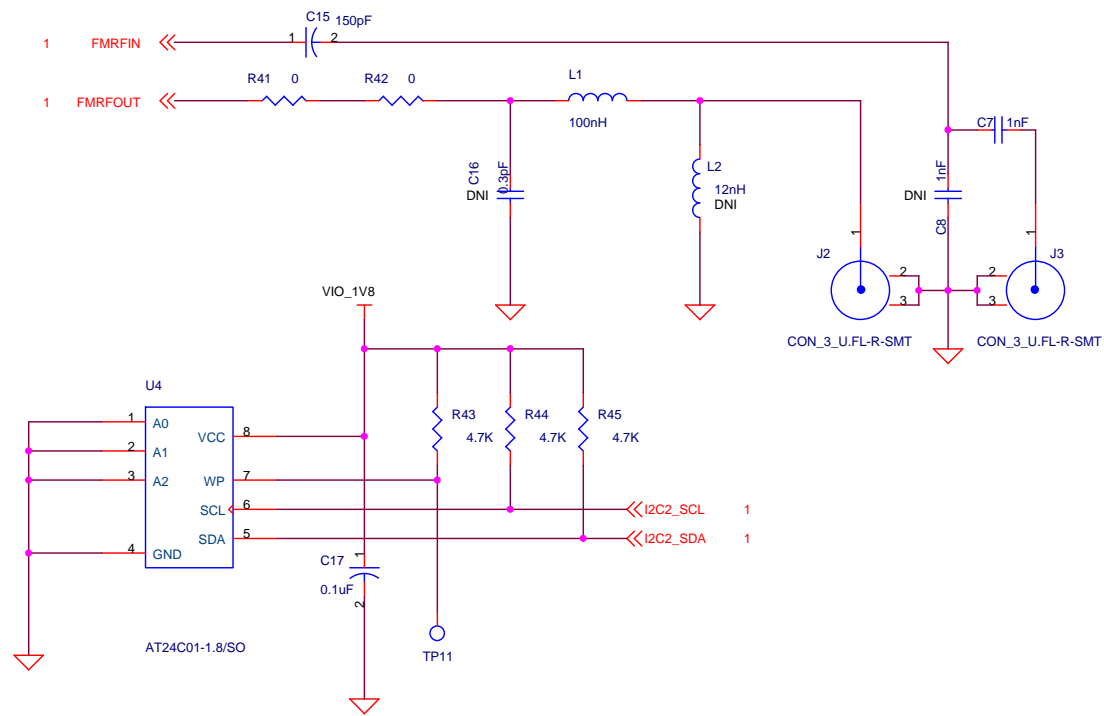

beagleboardtoys.com

1380 Presidential Dr. #100  
 Richardson, TX 75081  
 www.beagleboardtoys.com

Title		
EEPROM		
Size	Document Number	Rev
A	BBT-WLAN-SCH-001	A
Date:	Monday, April 11, 2011	Sheet 3 of 3